



# PRODUCT GUIDE

# CONTENTS



●  
**01**

Structural Additions &  
Options

●  
**10**

Fireplace Options

●  
**14**

Window Options

●  
**18**

Plumbing Options

●  
**28**

Electric Options

●  
**30**

Exterior Trim Options

●  
**32**

Exterior Door Options

●  
**36**

Siding & Shingle  
Options

●  
**38**

Cabinet Styles

●  
**42**

Specialty Cabinet &  
Range Hood Options

●  
**46**

Ceramic Tile Options

●  
**48**

Countertop Options

●  
**52**

Desk & Island Options

●  
**58**

Interior Door and Trim  
Options

●  
**60**

Flooring Options

●  
**64**

Interior Finish Options





**STRUCTURAL ADDITIONS  
& OPTIONS**



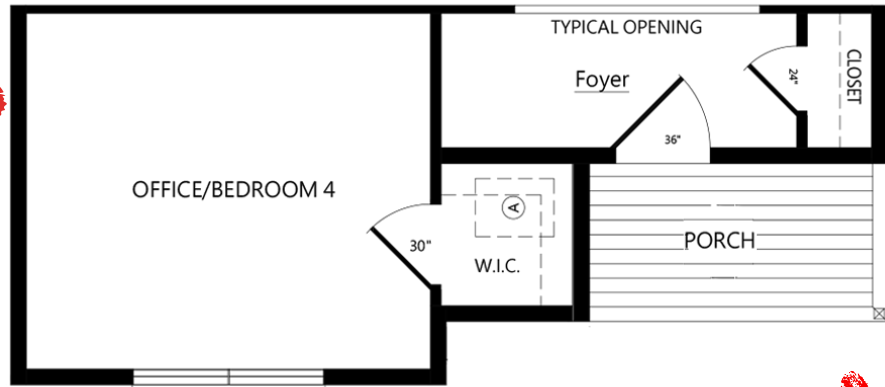
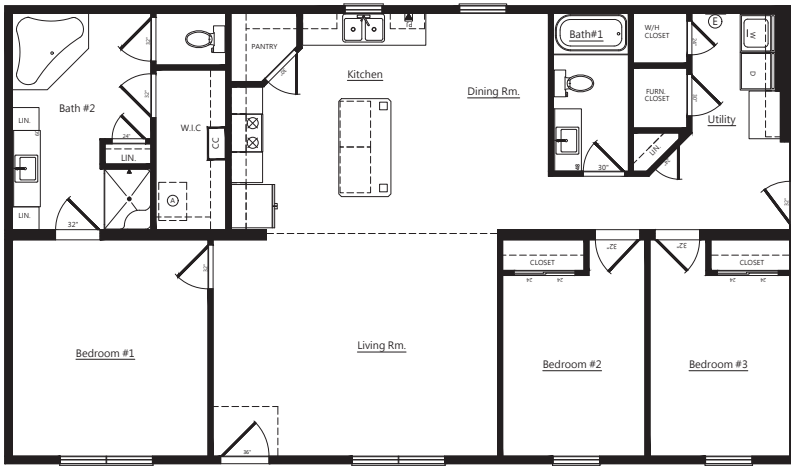

## ADD A THIRD BOX CONFIGURATION

There are many customizations that can be added to the design of our homes. With your builder, adding more square footage, garages, and porches on site is always an option. All of these are popular ideas when building a home and we have designed modules, or boxes, to specifically tackle several of these at once. These modules can be added to many of our floor plans and with this one addition, space for an extra bedroom, office, or even workout room can be added. Along with extra interior space, front porch additions can be added for a dramatic change in curb appeal as well as adding an outdoor living space.



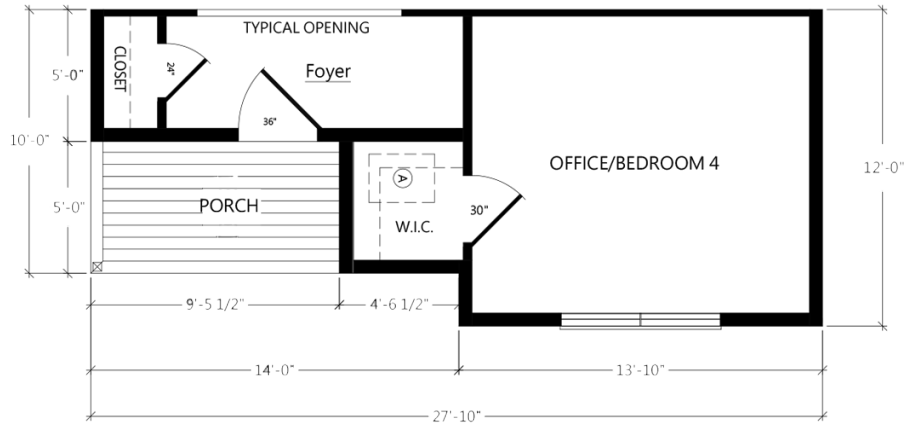

**PORCH UNIT A: OP2008R**

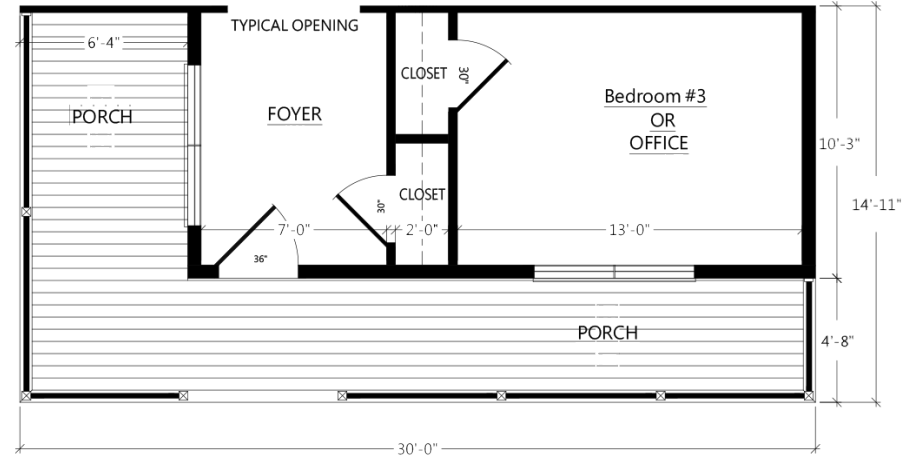

**PORCH UNIT B: OP2009R**

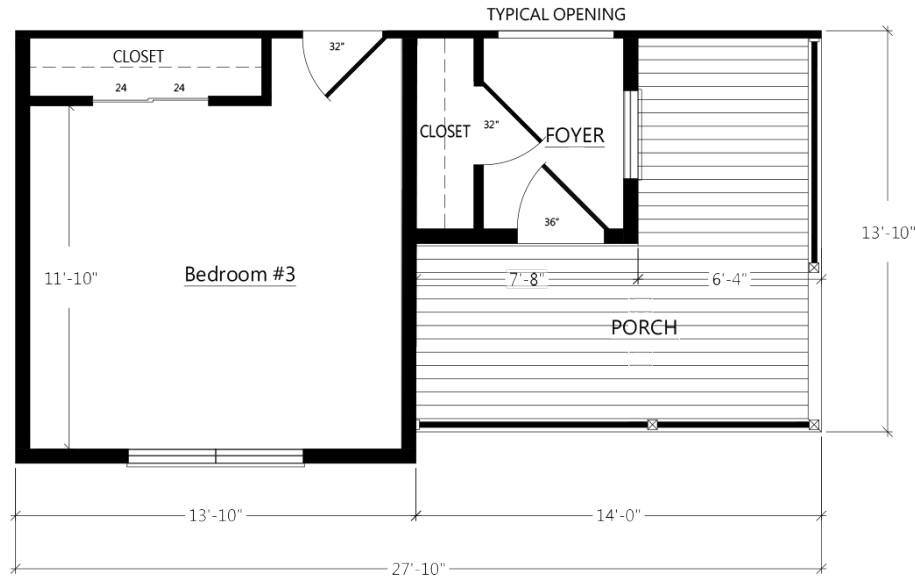

**PORCH UNIT C: OP2010R**

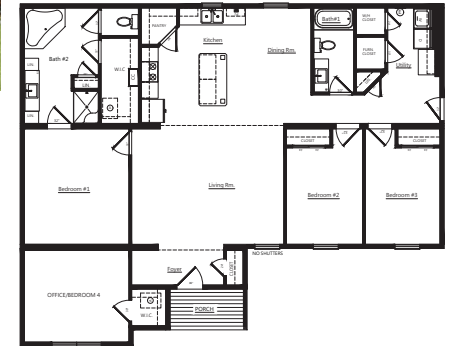



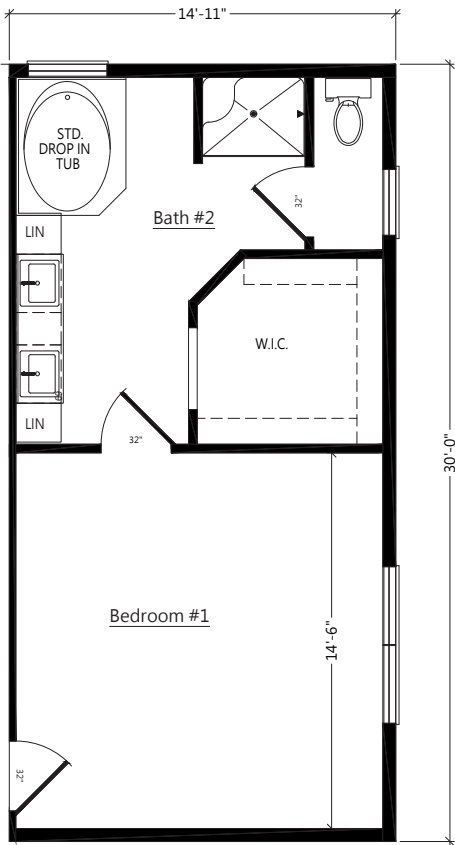

**BED BATH UNIT A: OP2003R**

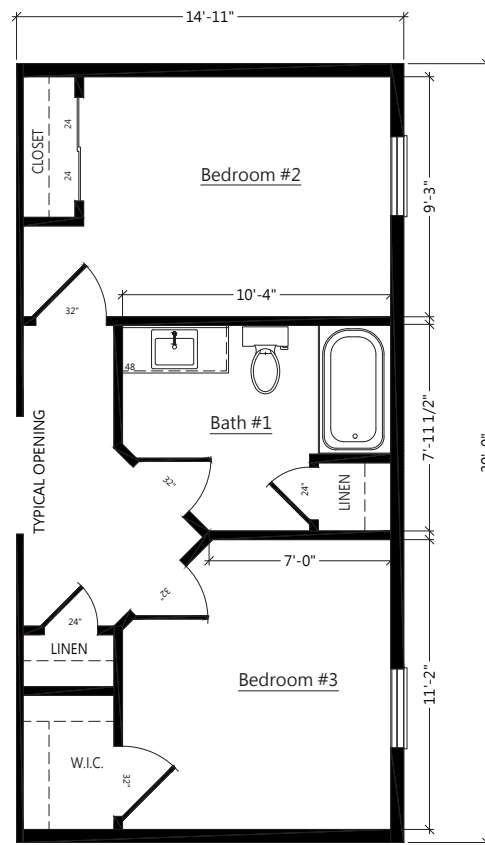

**BED BATH UNIT B: OP2004R**

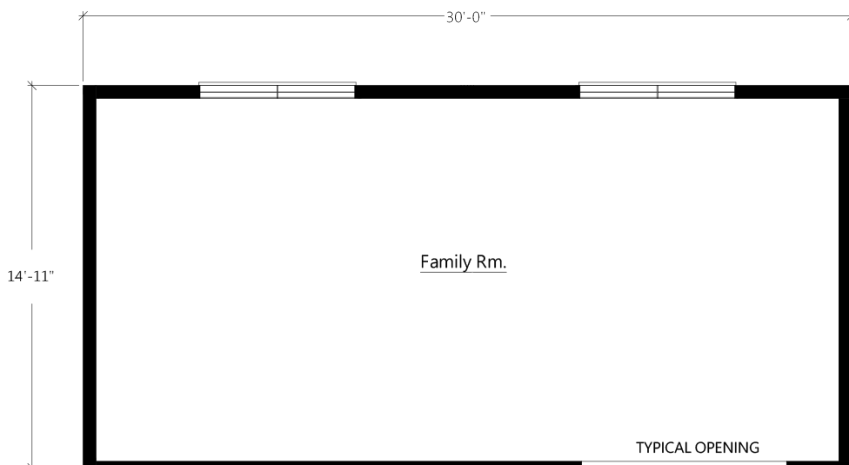

**FAMILY ROOM**

- 26ft: **OP2005R**
- 28ft: **OP2006R**
- 30ft: **OP2007R**



We have designed modules specific to getting more bedrooms and bathrooms in a home. These are especially appealing when added to one of our two story floor plans. Many people have used the bedroom addition modules for adding a main floor master suite or an in-law suite. Finally, we have a living room module that can be added to the side or back of almost any of our designs for additional living/family room. All of these additional boxes will enhance the dimension to a home creating a stunning exterior.



## WHAT IS A ROOF RETURN?

Roof returns are an option on some of our gables and bump outs, a familiar term for these are eyebrows. The shingled line of the roof shown on the left is a good example. A roof return can be used to add decoration to a gable or as a break between a change in exterior façade.

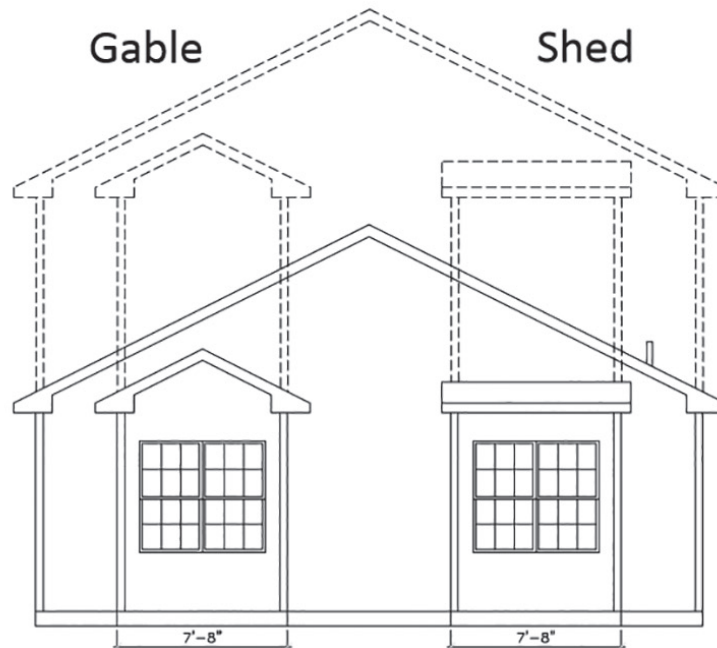

## GABLE VS SHED

We offer two roof profiles on our dormers and bump outs. A gable style roof, where the roof lines come to a peak at the front, can be used to accent a traditional, transitional, or Victorian style home. A shed roof is a low sloped roof that moves in the same directions as the main roof line of a home. Most people use shed roofs to provide a craftsman, transitional, or even modern look.



## DUTCH GABLE BUMP-OUT

Available on 6/12 or 9/12 Ranch or Two Story



No Roof Return Bump-out Shown with 8' Sidewalls, (2) 3050 Operable Windows, and Lineals.  
**OP2013AR**

Roof Return Bump-out Shown with 8' Sidewalls, (2) 3050 Operable Windows, and Lineals.  
**OP2014AR**



## GABLE BUMP-OUT

Available on 6/12 or 9/12 Ranch or Two Story



Roof Return Bump-out Shown with 8' Sidewalls, (2) 3050 Operable Windows, and Lineals.  
**Ranch: OP2016AR**  
**Two Story: OP2028R**

No Roof Return Bump-out Shown with 8' Sidewalls, (2) 3050 Operable Windows, and Shutters.  
**Ranch: OP2015AR**  
**Two Story: OP2024R**



## END WALL BUMP-OUT

Available on 6/12 or 9/12 Ranch or Two Story



10" Gable Bump Out Shown with 3050 windows  
**Ranch: OP2011AR**  
**Two Story: OP2019R**

10" Shed Bump-out Shown with 3050 windows  
**Ranch: OP2018AR**  
**Two Story: OP2020R**



## TWO STORY GABLE BUMP-OUT

Available on 6/12 or 9/12 Two Story



Square Window Bump-out with (2) 3050 Windows and Shutters  
**OP2024R**

## RECESSED ENTRY



Recessed entry with stone or siding to bottom of door.  
**Stone: OP2045AR**  
**Siding: OP2044AR**

## GABLE DORMERS



6' 1" Gable Dormer with 3050 operable or fixed window  
**OP2033R**  
Available 9/12 or 12/12



11' Wide Gable Dormer with (2) 3050 fixed or operable Windows  
**OP2031R**  
Available 12/12

## SHED DORMERS

Available 9/12 or 12/12



6' 1" Shed Dormer with 2030 operable or fixed Windows  
**OP2035R**

11' Wide Shed Dormer with (4) 2030 fixed or operable Windows  
**OP2034R**



## 8' COVERED PORCH

Available in 6/12, 9/12 Ranch Only

Full width porch or half width available. Porches can only be built on gable ends.  
**OP2002R**





# WHY YOU SHOULD ADD DORMERS



Adding one or more dormers to a roof's structure can turn a rather bland roofline into one with architectural interest and curb appeal. Not only do dormers improve the aesthetics of a home, but this upgrade will also make a home more appealing to buyers. When added to a home, dormers provide much-needed natural light and another view of the outdoors. Adding a large dormer will increase the usable space of a room. They are perfect spots for a reading nook, small office space or a kids' play area.



# BENEFITS OF A HIGHER ROOF PITCH

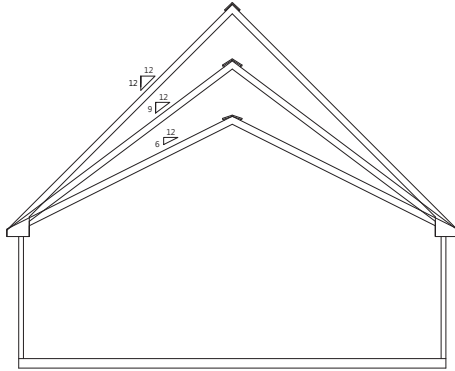

## STARTING WITH 6/12

All of our 2 box standard ranch homes begin as a 6/12 roof pitch. Upgrade to a 9/12 or a 12/12 roof pitch to take advantage of exterior options such as a higher roof pitch and the ability to add dormers.

## ATTIC SPACE & LIVING SPACE

A higher roof pitch encourages the development of larger attic spaces that are terrific for seasonal or long-term storage. The best part? This storage room often has very minimal installation expenses, as the space is already there. Depending on the pitch, there may even be enough space to convert this area into a functional living space. Many higher pitched roofs have windows installed for added natural light in the attic area.

## EXTERIOR APPEAL

Many people adore homes with a higher roof pitch because they offer more visibility to a roof. A roof with a low pitch is usually not visible from ground level. A higher pitch can play a significant role in adding curb appeal to your home. These roofs make a home look more ornate and prominent from the outside. They also allow for the addition of decorative caps, inventive designs, and gables to your building. Higher roof pitches can turn a simple architectural style into a more visually complex one with just a few finishing touches.



Non Habitable 9/12 with 3/4 deck and 2x6 attic endwalls with R25 insulation under floor. (habitable option available)

Habitable 12/12 with 3/4 deck and 2x6 endwalls. R30 insulation under floor



Stairway Rail System  
Handrail is not provided by RHI.  
**OP30033R**



**UPSTAIRS 12/12 FINISHED ON SITE**



## 9/12 CATHEDRAL



9/12 Cathedral shown with (2) 3/0 x 3/0 fixed windows & (1) 3/0 x 6/0 fixed window.

Also available with (2) optional patio doors.

### SILVERLINE

26 ft Wide: **OP3000R**  
 28 ft Wide: **OP3001R**  
 30 ft Wide: **OP3002R**

### ANDERSEN

26 ft Wide: **OP3075R**  
 28 ft Wide: **OP3076R**  
 30 ft Wide: **OP3077R**

## 12/12 LOFTED CAPE



12/12 Lofted Cape shown with (2) 3/0 x 3/0 fixed windows & (1) 6/0 x 6/0 fixed window.

Also available with (2) optional patio doors.

### SILVERLINE

26 ft Wide: **OP3025R**  
 28 ft Wide: **OP3028R**  
 30 ft Wide: **OP3031R**

### ANDERSEN

26 ft Wide: **OP3078R**  
 28 ft Wide: **OP3079R**  
 30 ft Wide: **OP3080R**

## LOFTED 9/12, FINISHED ON SITE

All cathedral and loft options have a similar interior to below



## 12/12 LOFTED CAPE



12/12 Lofted Cape shown with (2) fixed trapezoid windows & (1) fixed picture window. Also available with (2) optional patio doors.

### SILVERLINE

26 ft Wide: **OP3027R**  
 28 ft Wide: **OP3030R**

### ANDERSEN

26 ft Wide: **OP3026R**  
 28 ft Wide: **OP3029R**

12/12 Lofted Cape shown with (2) fixed trapezoid windows & (1) fixed twin picture window. Also available with (2) optional patio doors.

### SILVERLINE

30 ft Wide: **OP3032R**

### ANDERSEN

30 ft Wide: **OP3033R**





## **FIREPLACE OPTIONS**



# CUSTOMIZE YOUR FIREPLACE

Digital depictions of Fireplaces does not reflect actual final color



## STONE COLOR & STYLE



**BUCKS CREEK**



**CHARLESTON**



**GALVESTON GRAY**



**HAMPTON GRAY**



**GRAPHITE**



**PRICE**

## FARMHOUSE MANTLE

Wrap around mantle, stain matches trim package

\*Shiplap not available through RHI

OP4024R



## 60 INCH. BEAM MANTLES

Mantles constructed out of Maple

OP4023R



**Farmstead**

**Weathered**



## FIREPLACE A



**Fireplace A** Stone front corner fireplace. Shown with Charleston Stone & Traditional Mantle

Ranch Gas: **OP4001AR** Wood: **OP4000AR**

Cape Gas: **OP4002R** Wood: **OP4003R**

## FIREPLACE C



**Fireplace C** Stone front flat fireplace. Shown with Hampton Gray Stone & Traditional Mantle

Ranch Gas: **OP4006AR** Wood: **OP4007AR** Cape Gas: **OP4004R** Wood: **OP4005R**

## FIREPLACE F



**Fireplace F** Rave fireplace. Includes: Modern Fireplace with Black Trim

Ranch Gas: **OP4013AR**

Cape Gas: **OP4012R**

Note: \*Media prep outlet is not included

Digital depictions of Fireplaces does not reflect actual final color



## FIREPLACE E



**Fireplace E** Stone front half wall fireplace. Shown with Graphite Stone & Traditional Mantle.

Ranch Gas: **OP4010AR** Wood: **OP4011AR** Cape Gas: **OP4008R** Wood: **OP4009R**

## FIREPLACE H



**Fireplace H** Stone front fireplace with Farmhouse Mantle. Shown with Bucks Creek stone.

Ranch Gas: **OP4019AR** Wood: **OP4020AR**  
Cape Gas: **OP4018R** Wood: **OP4021R**

## FIREPLACE G



**Fireplace G** Farmhouse fireplace. Shown with Bucks Creek Stone front Fireplace. Shelving with raised hearth and mantel, windows, (4) can lights and (2) eyeball lights. Total Length: 17' 4"

Ranch Gas: **OP4017R**  
Wood: **OP4015R**  
Cape Gas: **OP4016R**  
Wood: **OP4014R**

Note: \*Media prep outlet is not included



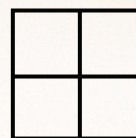

**WINDOW OPTIONS**

# KNOW YOUR WINDOWS

## SINGLE HUNG

Single-Hung windows allow ventilation through a single operable lower sash.

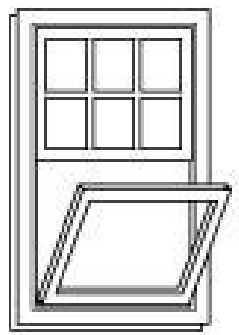

\*View from inside

## DOUBLE HUNG

Double-Hung windows have two operating sash that move up and down allowing for ventilation on the top, bottom or both.

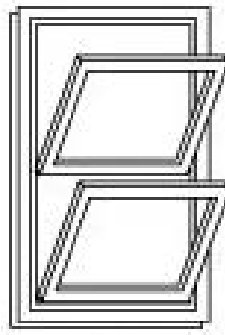

\*View from inside

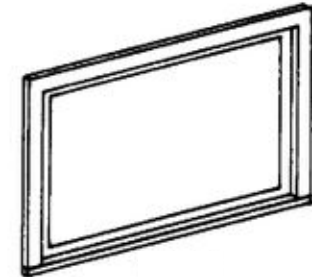

## TRANSOM WINDOW

A window above a door that is usually installed to a horizontal crosspiece over the door.



\*View from outside

## AWNING WINDOW

Awning windows are hinged on the top and open outward from the bottom, allowing for ventilation and protection from the rain. Often placed higher on walls for privacy or in combination with large stationary windows for a better view.

## CASEMENT WINDOW

Casement windows are hinged on the side and crank open outward to the left or right allowing for full top to bottom ventilation.

Standard above kitchen sinks, casement windows give you the flexibility to group them in stunning combinations.

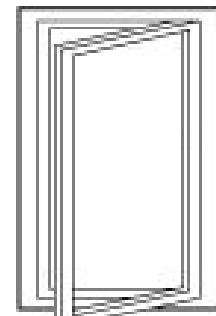

\*View from outside





## ADVANTAGES OF SILVERLINE

The Silverline Series offers a great vinyl window option that performs just as well as it looks.

- Low Maintenance Vinyl Interior and Exterior
- Standard with screen & colonial grids
- Casement Window in Kitchen, single hung
- 6' 0" Also available with 9' Sidewall Option
- Available in Double Hung
- Transoms also available
- Energy Star Rated
- Limited Lifetime Warranty

## SOME POPULAR SILVERLINE OPTIONS

Vinyl WDO 3050: [OP9038AR](#)

Vinyl WDO 3060: [OP9041R](#)

Vinyl WDO 2030 tempered glass additional: [OP9032AR](#)

Vinyl WDO 2630 tempered glass additional: [OP9037AR](#)

Vinyl WDO 4050 w/two flanking windows: [OP9045R](#)

Vinyl WDO Transom 12 inch: [OP9054AR](#)

Vinyl WDO Awning 3015: [OP9046R](#)

Vinyl WDO 2430 Casement additional: [OP9036AR](#)



White

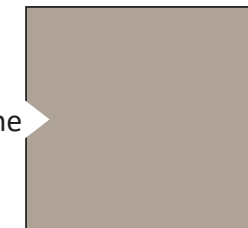

Sandtone



## ADVANTAGES OF ANDERSEN

The 400 Series brings you the best overall blend of performance and style to satisfy just about any window or patio door need.

- Interior Wood Painted
- Wood Frame with Exterior Vinyl Clad
- Wood Sashes with Flexacron Finished Exterior
- Standard with screen and colonial grids
- Standard Double Hung with Casement in Kitchen
- Energy Star Rated
- Limited Warranty

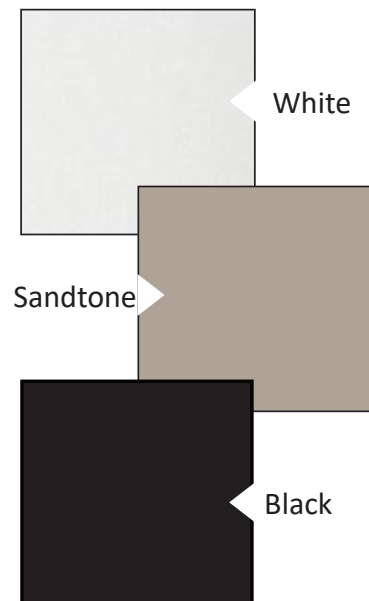

## SOME POPULAR ANDERSEN OPTIONS

- Andersen 400 WDO TW210410: [OP9017R](#)
- Andersen 400 WDO TW210510: [OP9020R](#)
- Andersen 400 WDO TW20210: [OP9014R](#)
- Andersen 400 WDO TW24120: [OP9021R](#)
- Andersen 400 WDO Picture 310410 w/ 2 flanking: [OP9011R](#)
- Andersen 400 WDO Transom: [OP9013R](#)
- Andersen 400 WDO AR31 Awning 3'x17": [OP9009R](#)
- Andersen 400 WDO CW13: [OP9010R](#)





## PLUMBING OPTIONS



# BEST SELLING SHOWERS!

\*All Tile showers are standard with Shluter edging

## SHOWER OH!



5'x5' shower pan with rainfall showerhead. Standard with two shower heads.

No shampoo niche

Ceramic IPO 48" shower in all three tile colors and with a transom window [OP6046R](#)

Panels IPO 48" shower, no window [OP6046R](#)

## SERENITY SHOWERS



### Shower N3

Serenity ceramic walk in shower, 1/2 wall, and glass, standard with block window, can light, rainfall showerhead, and Delta components

[OP6043R](#)

### Shower N4

Serenity ceramic walk in shower with full bench, 1/2 wall, and glass, standard with block window, can light, rainfall showerhead, and Delta components

[OP6044R](#)

## STANDARD SINKS



Standard stainless steel kitchen sink 8" depth



Standard China Lav Bowl  
\*Sinks come in square variation



Black Kitchen Sink  
-Crafted from Nickel Quartz  
-Stain, impact, heat, and scratch resistant  
-Sound-deadening material  
-Hygiene protection  
-9" depth  
**OP6051AR**

Kohler Vault Stainless Steel Single Bowl topmount, 10" depth  
**OP6055AR**



## OPTIONAL SINKS



Pedestal Sink  
**OP6057AR**

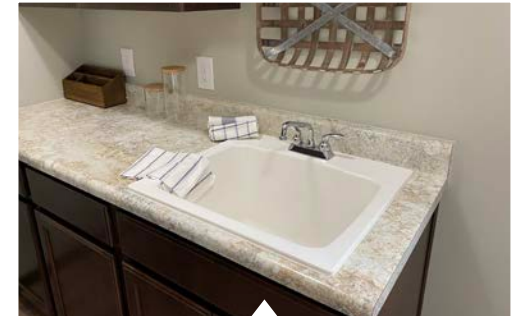

Washtub installed in cabinet  
**OP6059AR**



Double Lavs  
\*Sinks come in square variation  
**OP6053AR**



# CHOOSE YOUR FINISHES



see what Delta can do™



## BRUSHED NICKEL FAUCET PACKAGE - OP6017AR



Kitchen Faucet



Bathroom Faucet

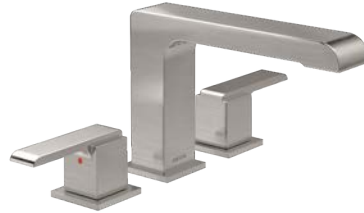

Stand Alone Tub Faucet



Shower Trim



Tub/Shower Trim

## MATTE BLACK FAUCET PACKAGE - OP6017AR



Kitchen Faucet



Bathroom Faucet



Stand Alone Tub Faucet

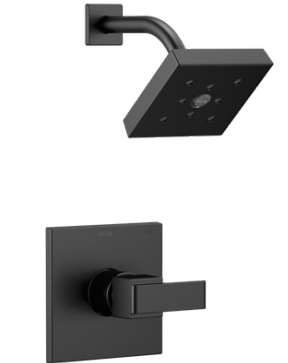

Shower Trim



Tub/Shower Trim

# CHOOSE YOUR FINISHES

## SERENITY/TRANQUILITY/SOWER OH! FAUCET OPTIONS



Valve Trim - OP6017AR  
-Brushed Nickel



Valve Trim - OP6017AR  
-Matte Black



Rain Showerhead - OP6017AR  
-Brushed Nickel



Rain Showerhead - OP6017AR  
-Matte Black



Showerhead - OP6017AR  
-Brushed Nickel



Showerhead - OP6017AR  
-Matte Black

## FAUCET UPGRADES



Bar Sink Faucet - OP6050AR  
-Brushed Nickel



Bar Sink Faucet - OP6050AR  
-Matte Black



Handheld Showerhead - OP6040AR  
-Brushed Nickel



Handheld Showerhead - OP6040AR  
-Matte Black



# SHOWER OPTIONS

\*All Tile showers are standard with Shluter edging



**Shower A**  
60" Tub/ Shower



**Shower C**  
48" shower with sliding enclosure in place of tub/shower.  
**OP6030AR**  
Available with ceramic on walls. No seat  
**OP6029R**



**Shower D**  
60" shower with enclosure in place of tub/shower.  
**OP6032AR**  
Available with ceramic on walls no seat.  
**OP6031R**

**Shower E**  
60x43 bench shower in place of standard tub/shower with enclosure.  
**OP6036AR**



## 60in Chrome Barn Shower Door

- Contemporary barn door w/ a minimalist design
- Slim stainless header with 18 in. handle
- Brushed Nickel Finish
- 78 3/4" high clear glass panel
- (Available with Shower OH! and 60in. Ceramic Only)

**OP6033R**

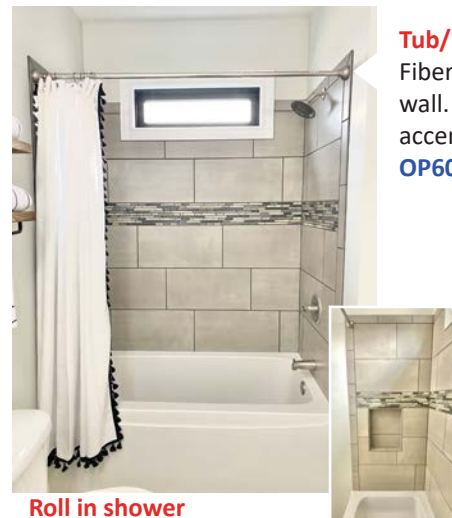

**Roll in shower**  
50x50 in place of standard w/(1) grab bar  
**OP6049AR**

Fold down seat in roll in shower **OP6038AR**  
Grab bar for tub/shower (1) **OP6039AR**  
Hand held shower head(shower head only)  
**OP6040AR**

## Tub/ Shower G

Fiberglass tub with ceramic tile on wall. Ivory, Calacatta, or Gray with accent. Includes shampoo niche.  
**OP6065R**



# TUB OPTIONS

\*All Tile showers are standard with Shluter edging



**Tub M**  
Ceramic backsplash for corner tub w/ (1) row of accent tile  
**OP6064R**



**Tub G**  
Drop in tub with laminate top

**Tub L**  
Ceramic top on drop in tub, with 45" of backsplash, one row of accent tile  
**OP6063R**



**Tub H**  
72" tub in place of standard  
**OP6067AR**



**Tub I**  
Corner Fit Tub



**Tub B**  
Garden/Tub shower in place of standard  
**OP6062AR**



**Free Standing Tub**  
Freestanding fiberglass tub in place of standard  
**OP6077AR**

## SHOWER TILE OPTIONS

- OP6069R** - Ceramic tile 12x24 with Silverado Grout
- OP6047R** - Shower OH! with Ceramic Tile IPO 48in. Shower and drop in Tub
- OP6048R** - Shower OH! with Ceramic Tile IPO 48in. Shower/Tub



# SERENITY SHOWERS

## N1 & N3



**Shower N1**  
Serenity ceramic walk in shower standard with block window (not shown), can light, rainfall showerhead, and Delta components  
**OP6041R**

**Shower N3**  
Serenity ceramic walk in shower, 1/2 wall, and glass, standard with block window, can light, rainfall showerhead, and Delta components  
**OP6043R**

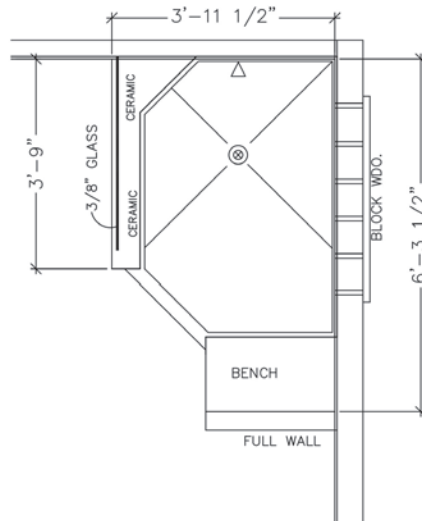

## N2 & N4

**Shower N2**  
Serenity ceramic walk in shower with full bench, standard with block window, can light, rainfall showerhead, and Delta components  
**OP6042R**

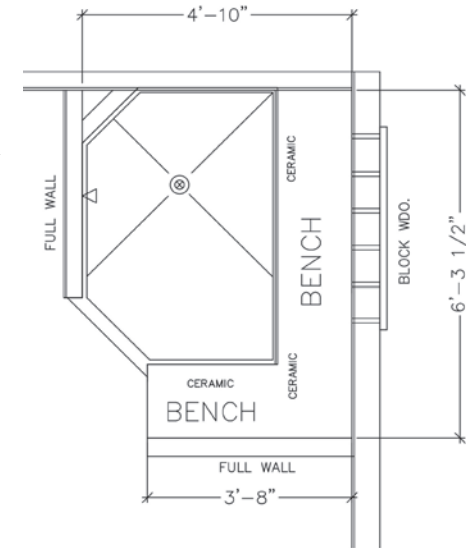

**Shower N4**  
Serenity ceramic walk in shower with full bench, 1/2 wall, and glass, standard with block window, can light, rainfall showerhead, and Delta components  
**OP6044R**

\*All Tile showers are standard with Shluter edging  
\*A Transom Window will replace the block window unless specified

# TRANQUILITY BATHS

## T1 & T2

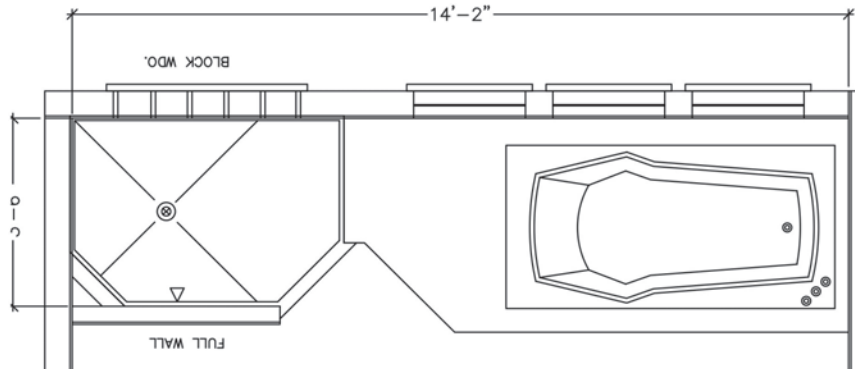

### Shower T1

Ceramic walk in shower with 72" tub, may change plan, total length 14' 2". Includes windows & shutters shown, can light, rainfall shower head and Delta components

**OP6021R**

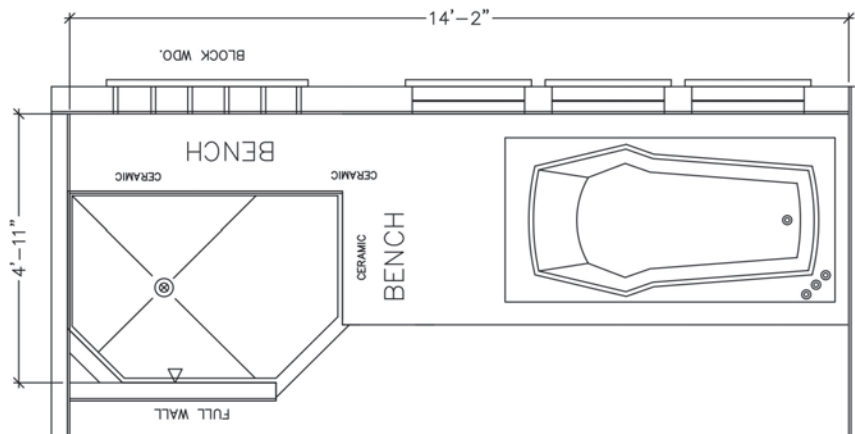

### Shower T2

Ceramic walk in shower with 72" tub, may change plan, total length 14' 2". Includes full bench, windows & shutters shown, can light, rainfall shower head, and Delta components

**OP6022R**

## T3 & T4

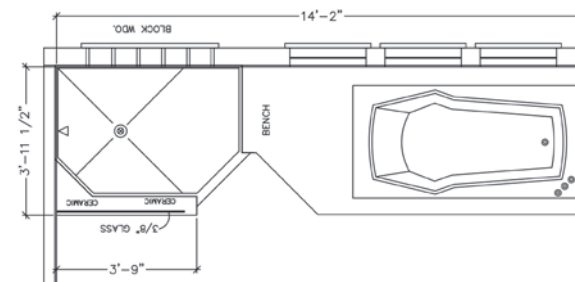

### Shower T3

Ceramic walk in shower with 72" tub, may change plan, total length 14' 2". Includes 1/2 wall, and glass, windows & shutters shown, can light, rainfall shower head and Delta components

**OP6023R**

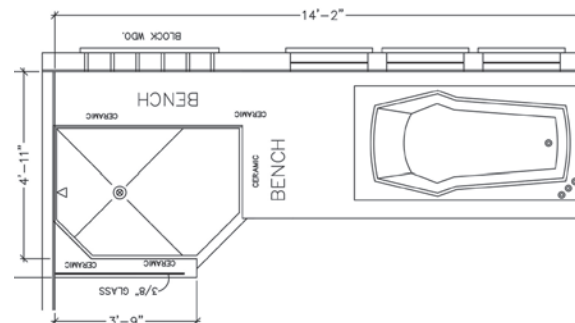

### Shower T4

Ceramic walk in shower with 72" tub, may change plan, total length 14' 2". Includes full bench, 1/2 wall with glass, windows and shutters shown, can light, and rainfall shower head Delta components.

**OP6024R**

\*All Tile showers are standard with Shluter edging  
\*A Transom Window will replace the block window unless specified









**ELECTRIC OPTIONS**



# STANDARD LIGHT FIXTURE OPTIONS - OP19013AR

## BRUSHED NICKEL



Dining Room Chandelier



Foyer Chandelier\*



Pendant Light



Flush Mount Light



Exterior Coach Light

## MATTE BLACK



Dining Room Chandelier



Foyer Chandelier\*



Pendant Light



Flush Mount Light

## ELECTRICAL OPTIONS



USB/Power in place of standard  
[OP7013AR](#)  
USB/Power outlet additional  
[OP7012AR](#)

White Can Light - Standard in Kitchen, Walk-in Closet, Utility, Hallway, and some Foyers

\*Foyer Chandelier is only available in Two-Stories



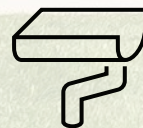

## EXTERIOR TRIM OPTIONS



# SHUTTERS

Raised Panel (Standard)/Board & Batten (Upgrade)



WINESTONE

DARK NAVY

WHITE

GRAY

BLACK



PEBBLESTONE

PEPPERCORN

SPANISH MOSS

BLACKWATCH GREEN

RED

CLAY



5 1/2" trim (shown) replace shutters white or clay  
 Ranch/Cape **OP11000AR**  
 Two Story **OP11002R**



EXT Trim-Sandtone/Clay trim package Ranch **OP11008AR** Two story **OP11005R** Cape Cod **OP11007R**  
 EXT Trim-Ranch Trim Package White: Window, Door, Drip Edge, Fascia, and Soffit **OP11006AR**  
 EXT Trim- Black trim package. Soffit, Fascia, Drip Edge **OP11026AR**  
 Board and Batten Shutters replace standard Ranch/Cape **OP11003AR** Two Story **OP11004R**



## EXTERIOR DOOR OPTIONS



# DOOR HANDLE OPTIONS

## STANDARD EXTERIOR DOOR HANDLE - OP19013AR



### FEATURES

- Exceeds criteria for BHMA Grade 3 certification
- Quality craftsmanship ensures durability and premium feel
- Lever design pairs well with the modern, clean lines of contemporary and urban design
- Covered under a limited lifetime mechanical and 5 year finish warranty



Brushed Nickel - Standard

Matte Black - Standard

# PATIO DOORS



Therma-Tru 2 panel hinged grids and screen  
**OP8063AR**



Vinyl 2 panel sliding with screen  
**OP8064AR**



RS130 6068 HPD Therma-Tru 2 panel hinged with blinds and screen  
**OP8065AR**



Andersen Perma Shield 2 panel gliding with screen. No grids. Int/Ext match  
**OP8062AR**



Andersen 2 panel sliding with screen. No grids. Ext. painted white.  
**OP8061AR**

# EXTERIOR DOOR OPTIONS

ALL DOORS AVAILABLE IN SMOOTH PAINT OR WOOD GRAIN STAIN



**Door A**  
 Smooth Painted  
 Upgrade Steel 6 Panel  
 Fire Rated 20 min.  
 Front or 90 min. Rear  
**OP8000AR**



**Door C: Full Axis Glass**  
 Painted      Wood Grain  
**OP8004AR    OP8003AR**  
 Sidelight:  
**OP8022AR    OP8021AR**  
 Transom:  
**OP8039AR    OP8040AR**



**Door D: 3/4 glass, 12 light**  
 Painted      Wood Grain  
**OP8006AR    OP8005AR**  
 Sidelight:  
**OP8024AR    OP8023AR**  
 Transom:  
**OP8041AR    OP8042AR**



**Door E: 6 Light, Raised Panel**  
 Painted      Wood Grain  
**OP8008AR    OP8007AR**  
 Sidelight:  
**OP8026AR    OP8025AR**  
 Transom:  
**OP8043AR    OP8044AR**

## PAINT COLORS

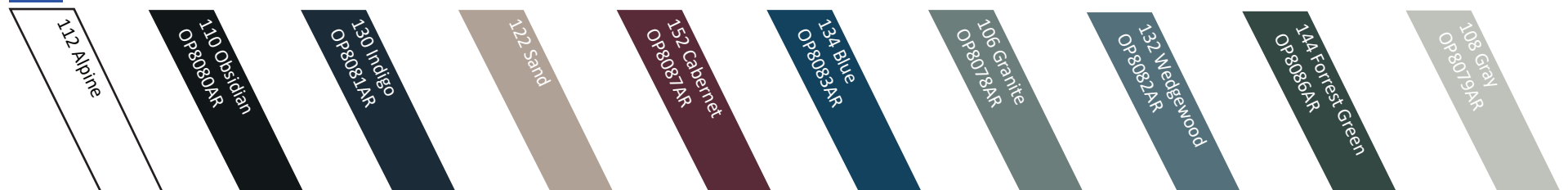





**Door F: 9 Light, Exterior Grids**  
 Painted      Wood Grain  
**OP8010AR   OP8009AR**  
 Sidelight:  
**OP8028AR   OP8027AR**  
 Transom:  
**OP8045AR   OP8046AR**



**Door G: 4 Light**  
 Painted      Wood Grain  
**OP8012AR   OP8011AR**  
 Sidelight:  
**OP8030AR   OP8029AR**  
 Transom:  
**OP8047AR   OP8048AR**



**Door H: Half Glass**  
 Painted      Wood Grain  
**OP8014AR   OP8013AR**  
 Sidelight:  
**OP8032AR   OP8031AR**  
 Transom:  
**OP8049AR   OP8050AR**



**Door I: Full Glass with Blinds**  
 Painted      Wood Grain  
**OP8016AR   OP8015AR**  
 Sidelight:  
**OP8034AR   OP8033AR**  
 Transom:  
**OP8051AR   OP8052AR**



**Door J: Sunburst, External Grids**  
 Painted      Wood Grain  
**OP8017AR   OP8091AR**  
 Sidelight:  
**OP8036AR   OP8035AR**  
 Transom:  
**OP8054AR   OP8053AR**

**STAIN COLORS**







**SIDING & SHINGLES**



# TRUDEFINITION DURATION SHINGLES

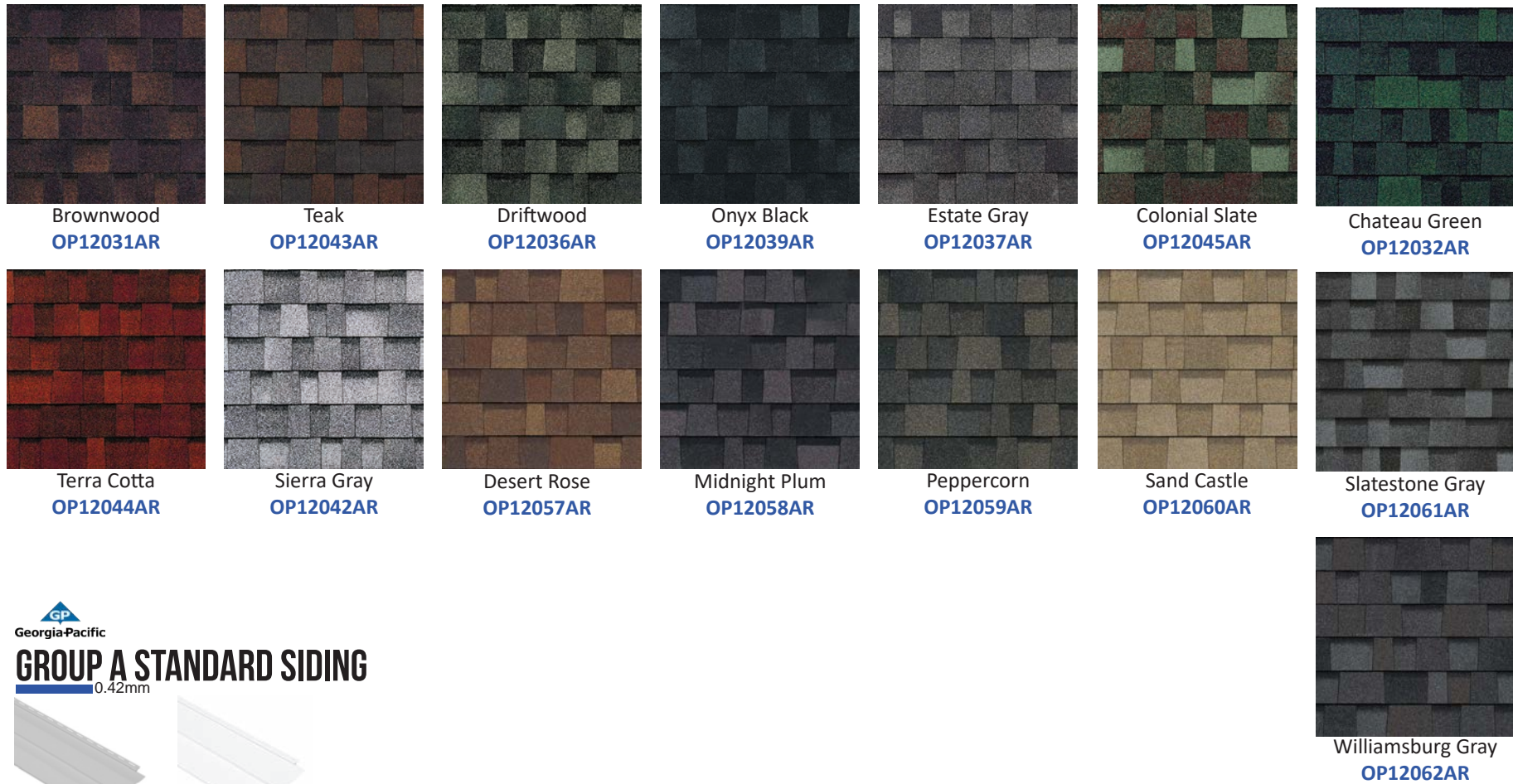

## GROUP A STANDARD SIDING



## GROUP B SIDING



## GROUP C SIDING



## STYLES



Siding groups A-D come in traditional lap.

Siding- Vinyl shingle in Gray, White, or Tan in place of:  
Standard Siding - **OP12027AR**  
Upgrade Siding - **OP12028AR**





**CABINET STYLES**



## STANDARD CABINET GROUP

Square recessed panel overhead and base cabinets-Partial Overlay

Ranch/Cape **OP13002AR**  
Two-Story **OP13000R**



**SPRING VALLEY  
MAPLE BOARDWALK**



**SPRING VALLEY  
MAPLE PECAN**



**SPRING VALLEY  
MAPLE DUSK**

## CABINET CONSTRUCTION



We are America's Cabinetmaker.

**Construction:** 3/4" Solid wood face frames, reinforced and aligned with dowels and adhesive.

**Drawers:** Front is 3/4" thick. Also have WhisperGlide 75# capacity glides. Deluxe drawer option with 5/8" dovetailed construction and full extension undermount glides with soft-action technology available.

**Roll Out Trays:** Base cabinet roll out trays optional

**Overhead Cabinet Shelves:** 3/4" thick fully adjustable overhead shelves

**Hinges:** 6-way adjustable self closing concealed hinges with limited life time warranty

**Warranty:** 10-25 year limited warranty depending on cabinets

## CABINET GROUP A

Square recessed panel overhead and base cabinets-Partial Overlay

Ranch/Cape **OP13005AR**  
Two-Story **OP13006R**



**SPRING VALLEY  
HICKORY NATURAL**



**MARLIN MAPLE  
BOARDWALK**



**MARLIN MAPLE  
PECAN**



**MARLIN MAPLE  
DUSK**

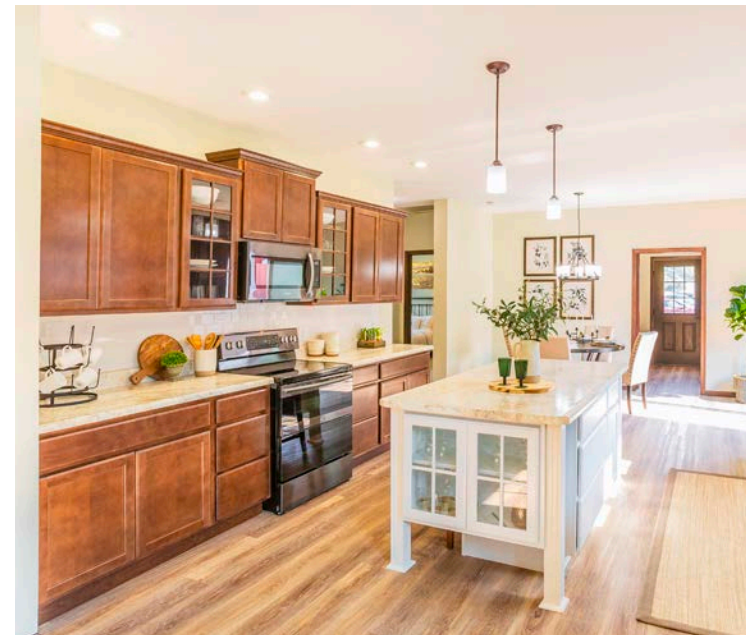

Note: Please see sample for true color

## CABINET GROUP B

Ranch/Cape [OP13009AR](#)

Two-Story [OP13010R](#)



**SPRING VALLEY  
MAPLE COTTON**



**SPRING VALLEY  
MAPLE GRAPHITE**



**SPRING VALLEY  
MAPLE NIGHTFALL**



**MARLIN MAPLE  
COTTON**



**MARLIN MAPLE  
GRAPHITE**



**MARLIN MAPLE  
NIGHTFALL**

## DELUXE DRAWER PACKAGE

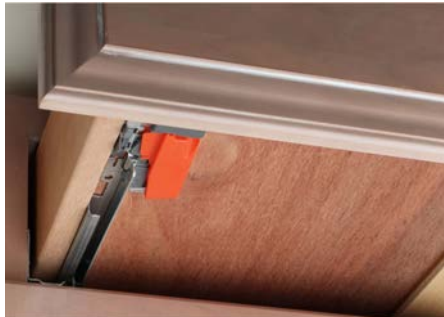

We are America's Cabinetmaker.

Available for classic line cabinets only in the Kitchen and Utility.

- Thicker core drawers- 5/8" thick drawer core provides a remarkably solid frame
- Dovetail drawer construction-durable and includes the SoftAction+ Tecnology on drawers only for a completely silent and effortless closing movement.
- Full extention drawers-allows the drawer to be completely opened.
- Plywood drawer bottom provides durable support to help resist sagging.

[OP13028AR](#) - Kitchen and Utility

[OP13029AR](#) - Kitchen, Utility and All Baths



Note: Please see sample for true color



## CABINET GROUP C

Ranch/Cape **OP13019R**  
Two-Story **OP13014R**

Square recessed panel overhead  
and base cabinets- Full Overlay



**RALSTON MAPLE  
BOARDWALK**



**RALSTON MAPLE  
PECAN**



**RALSTON MAPLE  
DUSK**



## CABINET GROUP D

Ranch/Cape **OP13036R**  
Two-Story **OP13018R**

Square recessed panel overhead  
and base cabinets- Full Overlay



**RALSTON  
MAPLE COTTON**



**RALSTON  
MAPLE GRAPHITE**

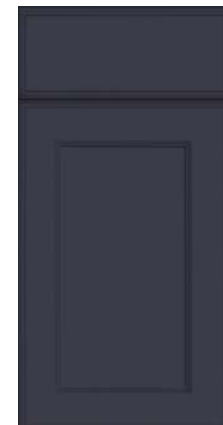

**RALSTON  
MAPLE NIGHTFALL**

Note: Please see sample for true color





**SPECIALTY CAB/  
RANGE HOOD**



## STAINLESS STEEL WALL MOUNT

Stainless steel wall mount with ceramic back splash vented outside. Optional with extended glass and 36" opening with 30" range hood [OP14015R](#)



## MAKE UP VANITY

42in. Wide Makeup Vanity w/ Countertop , Includes 12in. 3DBOD \*Vertical Cabinet not included [OP14045AR](#)



## SPECIALTY CABINETS ADDITIONS

- [OP14039AR](#) - Vanity storage over commode
- [OP7011AR](#) - Under cabinet lighting
- [OP14003AR](#) - 18" Additional bank of drawers
- [OP13027AR](#) - Base cabinet roll out tray



Standard bathroom with trimmed mirror, pendant lights, and bank of drawers

## OVERHEAD CABINET OPTIONS



Wall Wine Storage Cabinet  
**OP14043AR**



24" overhead open  
 bookshelf with organizer in  
 place of overhead 2430  
**OP14018AR**



Glass door on wall  
 straight cabinet 15" or 18"  
 square to match cabinets  
**OP14033AR**

## BASE CABINET OPTIONS



Double base waste basket  
 top mount  
**OP14028AR**

36" base pots and pans  
 2-Drawer in place of  
 standard  
**OP14020AR**



9" base pull out pantry in  
 place of standard cabinet  
**OP14023AR**



36" base pots and pans  
 3-Drawer in place of  
 standard  
**OP14019AR**



Tilt out sink tray  
**OP14036AR**





36" Pantry with swing out racks in place of 18"  
**OP14000AR**

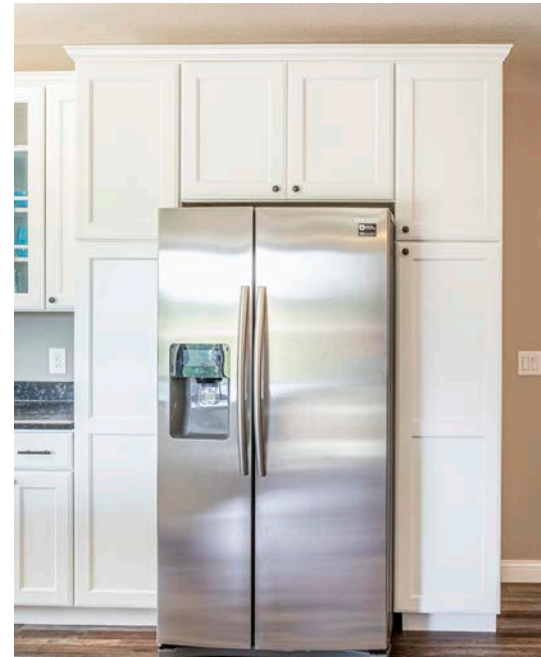

Double pantry surround refrigerator  
**OP14029AR**



Enclosed refrigerator  
36 x 72/stacked washer/dryer. 30/78 opening with 24" deep overhead cabinet  
**OP14030AR**



Universal wall oven unit in place of base and overhead

**OP14038AR**

Universal wall oven unit additional cabinet

**OP14037AR**

33"x90" w/30" Overhead Cabinets  
33"x96" w/42" Overhead Cabinets  
Appliance Opening Width 27"-31"  
Opening Height 23 3/4"-47 1/4"  
with two drawers below.

36in wide Bench and overhead in UTL with countertop

**OP14044AR**





**CERAMIC TILE**



## CERAMIC TILE COLORS



**IVORY** 12X24



**CALACATTA** 12X24



**GRAY** 12X24

## TILE OPTIONS

### **BATHROOM**

See Plumbing Options for showers available in ceramic. Only available in Silverado Grout.

### **KITCHEN**

**OP14015R** - Rangehood - Stainless Steel wall mount with Ceramic Tile, Vented Outside. Choose grout color.

**OP14017R** - Rangehood - Stainless Steel wall mount with Subway Tile, Vented Outside. Choose grout color.

**OP14016R** - Rangehood - Stainless Steel wall mount with Decorative Tile, Vented Outside. Choose grout color.

**OP14010R** - Ceramic tile between backsplash and upper cabinet. Choose grout color.

**OP14012R** - Subway Tile - Installed in a brick pattern. Choose grout color.

**OP14011R** - Ceramic decorative accent tile, between backsplash and upper cabinet.

## GROUT COLORS



**SILVERADO**



**RAVEN**

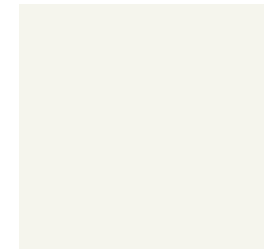

**BRIGHT WHITE**

## ACCENT TILE



**MOSAIC**





**COUNTERTOPS**



## TOP QUARTZ COLORS



CALACATTA LAZA



ICED GRAY



CARARRA MORRO



SOAPSTONE METROPOLIS

## ADVANTAGES TO UPGRADING TO QUARTZ

We offer two countertop materials. Laminate countertops are a wood-based counter with a laminated print for a surface. A laminate countertop offers great affordability and has many styles to choose from. We choose to build our homes with a post form, rolled edge laminate top so that there are no seams from the front of your countertop all the way to the backsplash, which prevents damage from water penetrating seams or from physical damage to the top. If you choose to upgrade to a solid surface countertop, we move straight to the hardest top in the industry. Quartz is a manufactured product that has grown in popularity because of its durability, lack of need for major time in upkeep, and beautiful, eye-catching designs.



## STANDARD COUNTERTOP COLORS

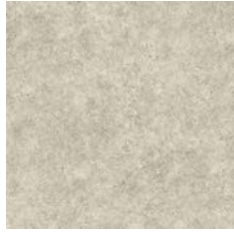

Pebble Piazza  
(5009-60)  
**OP15008AR**



Oiled Soapstone  
(4882-38)  
**OP15007AR**



White Juparana  
(4931-38)  
**OP15011AR**



White Cascade  
(5003-38)  
**OP15010AR**



Calacatta Oro  
(4981-38)  
**OP15003AR**



Milano Quartz  
(4726-60)  
**OP15005AR**



Natural Canvas  
(7022-58)  
**OP15006AR**

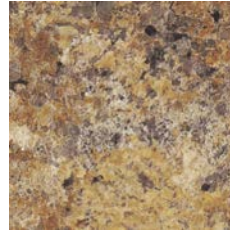

Butterum Granite  
(7732-58)  
**OP15002AR**

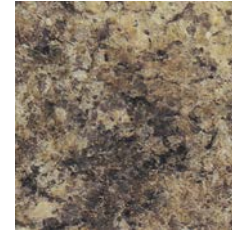

Jamocho Granite  
(7734-58)  
**OP15004AR**



White Carrara  
(4924-38)  
**OP15009AR**

## UPGRADE COUNTERTOP COLORS



Marmo Bianco  
(1885K-07)  
**OP15047AR**



Drama Marble  
(5010K-07)  
**OP15048AR**



Italian White di Pesco  
(4954K-22)  
**OP15044AR**



Typhoon Ice  
(4952K-22)  
**OP15049AR**

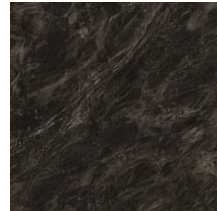

Sombra  
(5028K-07)  
**OP15050AR**



Crema Mascarello  
(3422-RD)  
**OP15041AR**



Dolce Vita  
(3420-46)  
**OP15042AR**



Calacatta Marble  
(3460-46)  
**OP15036AR**



Argento Romano  
(6697-46)  
**OP15038AR**



Azul Aran  
(9303-RD)  
**OP15039AR**



Glacier Quartzite  
(5025K-22)  
**OP15046AR**



Antique Mascarello  
(3466-RD)  
**OP15037AR**



Fantasy Marble  
(9301-34)  
**OP15043AR**



Cafe Azul  
(6319-RD)  
**OP15040AR**

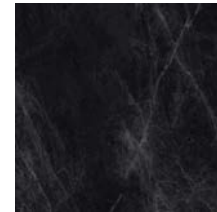

Jet Sequoia  
(3476-46)  
**OP15045AR**



## QUARTZ COUNTERTOP-GROUP A



Frost White  
(QSL-FRSTWHT)  
**OP15065R**

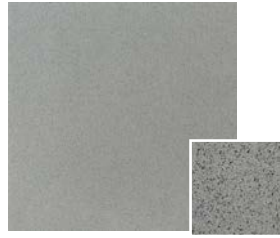

Iced Gray  
(QSL-ICEDGRY)  
**OP15064R**



Sparkling White  
(QSL-SPRWHT)  
**OP15071R**

## QUARTZ COUNTERTOP-GROUP B



Manhattan Gray  
(QSL-MANHATGRY)  
**OP15079R**

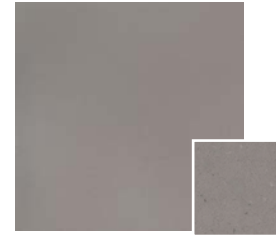

Fossil Gray  
(QSL-FOSGRY)  
**OP15075R**



Cararra Mist  
(QSL-CARRMIST)  
**OP15077R**



Helix  
(2143/I110203)  
**OP15094R**



Cararra Morro  
(QSL-CARMORRO)  
**OP15074R**

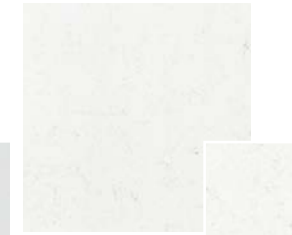

Miami Vena  
(2145/I110203)  
**OP15095R**

## QUARTZ COUNTERTOP-GROUP C



Calacatta Laza  
(QSL-CALALAZA)  
**OP15087R**



Soapstone Metropolis  
(QSL-SPSTNMETROPOLIS)  
**OP15083R**



Coral Clay  
(2242/I110203)  
**OP15096R**



Desert Silver  
(2218/I110203)  
**OP15097R**

### COUNTERTOP THICKNESS

All quartz groups will be 3cm thick in the Kitchen and 2cm thick in the bathrooms.



## DESKS & ISLANDS



Kitchen islands have become a real icon of the modern kitchen. Our kitchen islands come in a variety of shapes and sizes, and have the ability to be interchanged with a similar sized island to the one on the original plan.

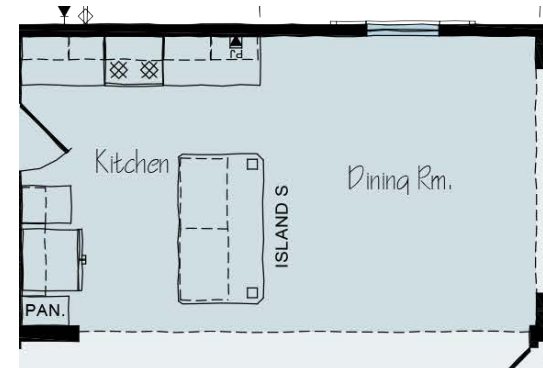
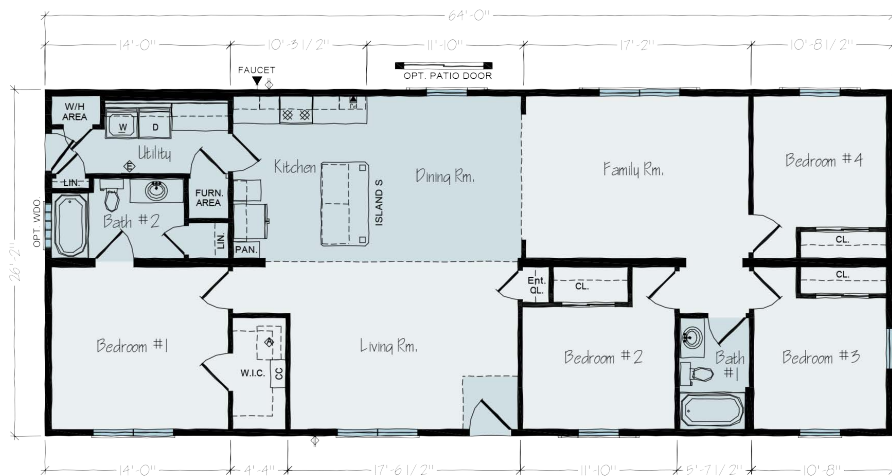
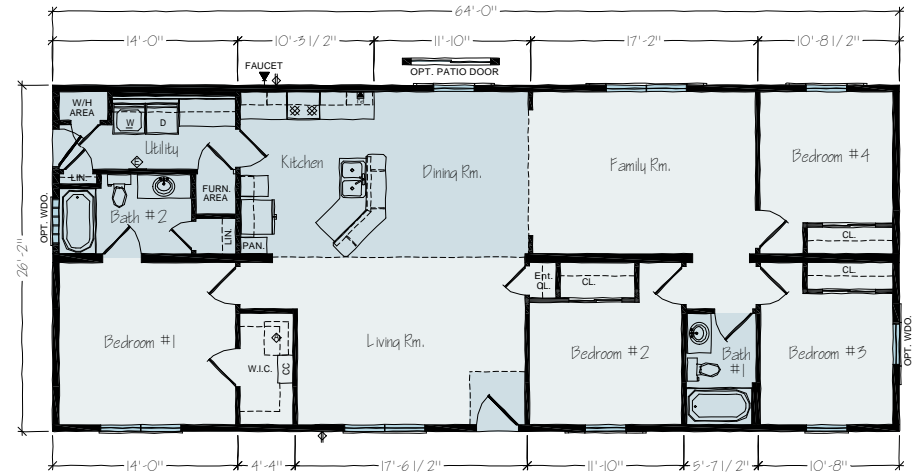

# STANDARD DESK



**Desk A** Kitchen Unit  
OP16000AR



**Desk B** 60" Hall Unit  
OP16001AR



**Desk C** 57"x57" Corner Unit  
OP16002AR



**Desk D** 81" Office Unit  
OP16003AR



**Desk E** 135" Office Unit  
OP16004AR



# ISLANDS



**Island A**  
4'3"x2'3" Island with 1" overhang all sides and receptacle on one end.  
**OP16005AR**



**Island I**  
6'4"x3'3" Island with overhang, kneehole on backside, glass doors square on one end and solid doors on opposite end, fluted legs at each corner and receptacle on backside of solid door cabinet.  
**OP16010AR**



**Island B**  
4'3"x3' Island with 1" overhang on front and sides and 11" overhang on backside and receptacle on one end.  
**OP16006AR**

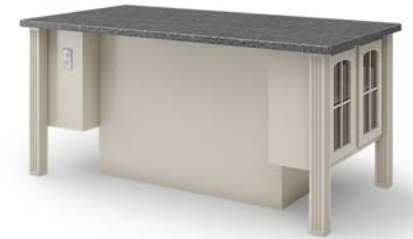

**Island J**  
6'9"x3'6 1/2" Island with 1" overhang on front and one side, raised bar with 13" overhang on back with leg supports, 24"x42" shelf section on side, receptacle on one end.  
**OP16011AR**



**Island E**  
Angled Island with 1" overhang on front and sides, 11" overhang on backside with receptacle on one end **OP16007AR**



**Island F**  
Angled Island with 1" overhang on front and sides, raised bar with 13" overhang on backside, receptacle on one end.  
**OP16008AR**  
Stone Backing **OP16009AR**





**Island K**  
 Double angle island with 1" overhang on front and sides, raised bar with 13" overhang on backside, receptacle on both ends. (Shown with sink, will accommodate dishwasher)  
**OP16012AR**  
**OP16013AR** (stone backing)

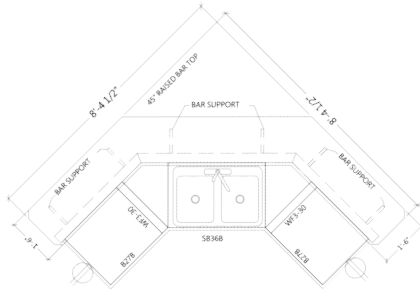

**Island L**  
 Double angle Island with 1" overhang on front and sides, raised bar with 13" overhang on back with supports, receptacle on one end.  
**OP16014AR**

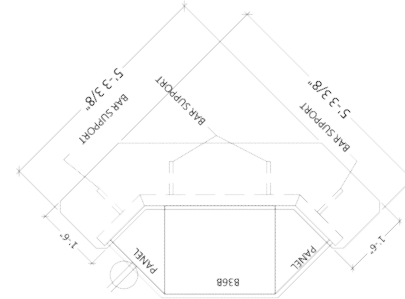

**Island N**  
 4'6"x3'1" Island with 11" overhang on back, full leg supports each end and receptacle on one end.  
**OP16015AR**



**Island S**  
 6'5"x3'5" Island with overhang on back, (2) pots and pans drawers, and (2) straight legs. Receptacle on one end  
**OP16019AR**







**Island T**  
 9'4"x4'2"  
 (2) large pots and pans drawers, and (2) straight legs  
**OP16020AR**



**Island Q**  
 8'4"x3'5" island with overhang on back, bookshelf on side.  
**OP16017AR**



**Island P**  
 6'4"x3'5" island with overhang on back, (2) 4 bank of drawers. 39" cabinet on side.  
**OP16016AR**



**Island R**  
 5'4"x3'5" island with overhang on back, 2 drawer pots and pans. 39" cabinet on side.  
**OP16018AR**





grateful  
love  
the ROWES  
thankful  
faith  
blessed



## INTERIOR DOORS & TRIM





**6 PANEL DOOR**



**3 PANEL DOOR**



**2 PANEL DOOR**

## TRIM PACKAGES

**OP17017AR-STANDARD PACKAGE** - Any door style in hollow core only, Trim Style 1, white only

**OP17025R-PACKAGE A** - Any door style in solid core, Trim Style 1, white or coffee

**OP17026R-PACKAGE B** - Any door style in solid core, Trim Style 2, white only, mitered on doors and windows.

**OP17027R-PACKAGE C** - Alder 3 Panel Door; Flat Sappy Cherry 3" casing, 4" base trim, butted installation.

## BARN DOOR HARDWARE



Brushed Nickel or Matte Black barn door hardware on door to match **OP17001AR**

Optional Pocket Doors (without privacy lockset)

**OP17013AR**  
Optional Pocket Doors (with privacy lockset)

**OP17014AR**

## TRIM COLOR

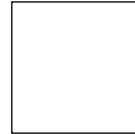

**WHITE**



**COFFEE**

## TRIM STYLE

### STYLE 1 (STANDARD & PACKAGE A)

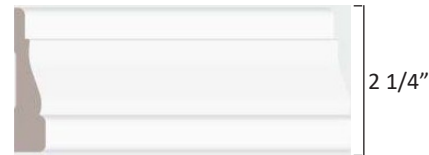

**CASING**

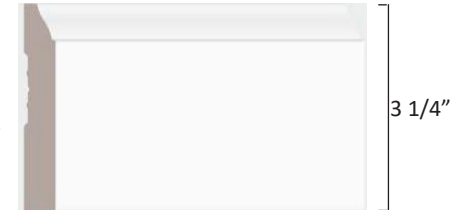

**BASEBOARD**

### STYLE 2 (PACKAGE B)

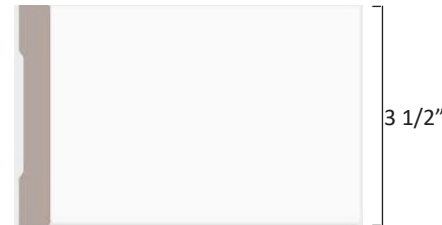

**CASING**

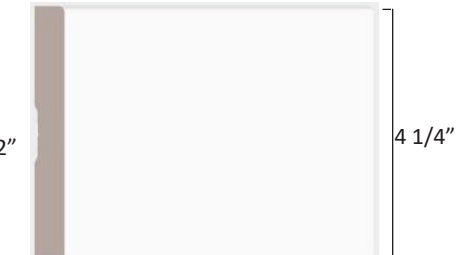

**BASEBOARD**

## PACKAGE C



**ALDER DOOR**



**CASING**

3"

**BASEBOARD**

4"



**SAPPY CHERRY TRIM**



**FLOORING**



## ADVANTAGE SERIES CARPET

### Take Away Carpet

- Nylon fibers and Polypropylene backing
- CRI Certification
- Recyclable
- Resilient
- 15 oz. Carpet



00128 Wells Beach  
**OP18018A**



00512 Driftwood  
**OP18016A**



00502 Shadow  
**OP18017A**



00703 Canoe  
**OP18063A**

## STANDARD VINYL FLOORING



Meteor Highlight  
LX301 **OP18066AR**

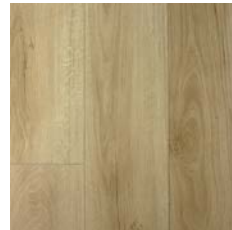

European Oak Aspen  
LX327 **OP18027AR**



European Oak Thunder  
LX325 **OP18067AR**

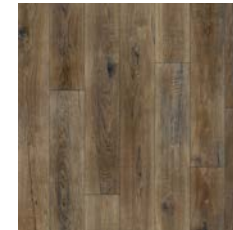

Aged European Oak Farmstead  
LX310 **OP18019AR**



Aged European Oak Natural  
LX311 **OP18068AR**

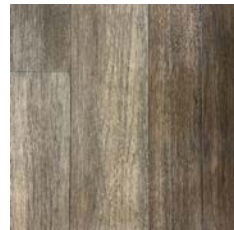

Artisan Dusky Acorn  
LX350 **OP18069AR**



Barn Wood Vintage White  
LX275 **OP18022AR**



Barn Wood Greige  
LX277 **OP18021AR**



Beachside Sundance  
LX355 **OP18070AR**

## ROCHESTER SERIES “OF COURSE WE CAN” CARPET 45 OZ.



00100 Linen  
OP18029AR



00102 Biscotti  
OP18030AR



00104 Arbor  
OP18031AR



00501 Ashes  
OP18032AR



00500 Dynamic  
OP18033AR



00502 Shadow  
OP18034AR



00105 Sepia  
OP18036AR



00504 Boulder  
OP18035AR



00106 Cloud Cover  
OP18037AR

## ROCHESTER SERIES “YES YOU CAN” CARPET 60 OZ.

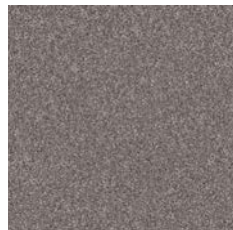

00509 Vintage  
OP18038AR



00502 Shadow  
OP18039AR



00107 Frozen  
OP18040AR

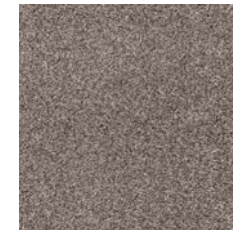

00116 Warm Light  
OP18041AR



00705 Mission Ridge  
OP18043AR



00109 Natural  
OP18042AR



00113 Cameo  
OP18064AR

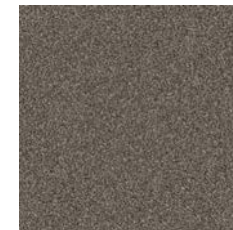

00708 Urban Rustic  
OP18065AR



# GENCORE PLANK FLOORING - 7.08" X 48.03



- Embossed Wear Layer
- High Definition Printed Film
- Rigid Core
- Patented Interlocking System
- Limited Warranty
- 100% Waterproof

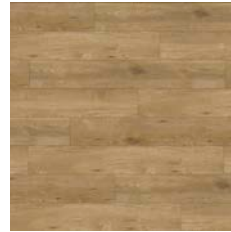

Bedford LUM-108  
**OP18066R**



Gansavort LUM-110  
**OP18067R**



Grove LUM-111  
**OP18068R**



Jane LUM-114  
**OP18069R**

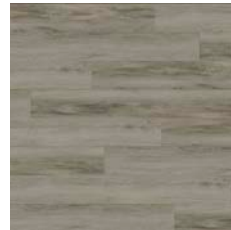

Fairview LUM-804  
**OP18070R**



Salem LUM-805  
**OP18071R**



Avon LUM-809  
**OP18072R**

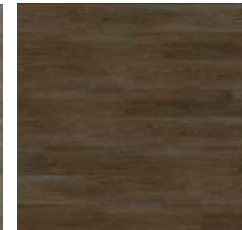

Roan LUM-811  
**OP18073R**



**INTERIOR FINISH**



## COLUMNS



Fluted wood column to match trim per pair  
**OP19007AR**

Grand Archway 5' arch with fluted columns, wood capped 1/4 walls  
**OP19001AR**



## INTERIOR FINISHES



Closet Organizer Component  
Additional. White Only  
**OP19014AR**  
\*standard in Master Walk-in Closet



Passage Door Lever  
-Brushed Nickel



Passage Door Lever  
-Matte Black



Privacy Door Lever  
-Brushed Nickel



Privacy Door Lever  
-Matte Black

## DRYWALL OPTIONS



Drywall arch  
4' **OP19008AR**  
5' **OP19009AR**

Large opening drywall arch  
**OP19010AR**



Coffered Ceiling with white crown moulding  
**OP19002AR**

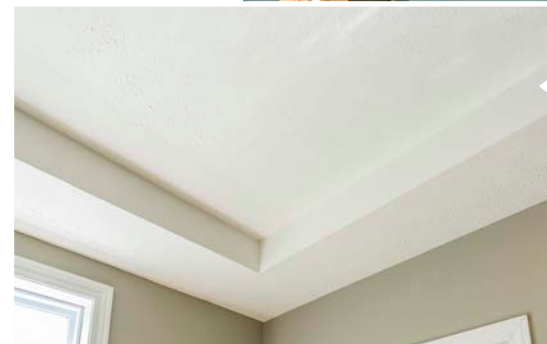

Tray Ceiling with 4 recessed can lights  
**OP19011AR**



1345 N. LUCAS ST. | ROCHESTER, INDIANA 46975

TOLL-FREE: 800.860.4554

LOCAL: 574.223.4321

FAX: 574.223.1655